

# NX-series IO-Link Master Unit

# NX-ILM400

**IO-Link makes sensor level information visible and solves the three major issues at manufacturing sites!**  
**The screwless clamping terminal block reduces wiring work.**



- Downtime can be reduced.  
Notifies you of faulty parts and such phenomena in the Sensor in real time.
- The frequency of sudden failure can be decreased.  
Condition monitoring of sensors and equipment to prevent troubles.
- The efficiency of changeover can be improved.  
The batch check for individual sensor IDs significantly decreases commissioning time.



Corresponding to our shared **Value Design for Panel** concept for the specifications of products

## Features

- The host controller can cyclically read control signals, status\*1, wiring, and power supply status of IO-Link sensors. Because an IO-Link System can cyclically read analog data such as the amount of incident light in addition to ON/OFF information, it can be used for predictive maintenance based on detection of such things as decreases in the amount of light.
- User-specified data in IO-Link devices can be read and written from the host controller when necessary.
- Digital signals can be input rapidly from IO-Link sensors\*2 during IO-Link communications.
- IO-Link sensors can be combined with non-IO-Link sensors.
- Incorrect connections of IO-Link sensors can be checked when IO-Link communications start.
- Backup and restoration of IO-Link device parameters\*3 make replacement of IO-Link sensors easier.
- Sensors can report their errors to the master, which facilitates locating errors from the host.
- The total number of retries in cyclic communications can be recorded. You can use this value to check for the influences of noise and other problems.  
(When EtherCAT is used as the host communication interface) \*3
- Up to four sensors can be connected.

\*1. Examples for Photoelectric Sensors: Instability detection and sensor errors

\*2. IO-Link sensors that support digital inputs that use pin 2 of IO-Link Master Unit ports

\*3. When the Omron IO-Link master unit is used

## Communications Specifications

Item	Specification
Communications protocol	IO-Link protocol
Baud rate	COM1 (4.8 kbps), COM2 (38.4 kbps), or COM3 (230.4 kbps)
Topology	1:1
Communications media	Unshielded cable
Communications distance	20 m max.
Compliant standards	<ul style="list-style-type: none"> <li>• IO-Link Interface and System Specification Version 1.1.2 *</li> <li>• IO-Link Test Specification Version 1.1.2</li> </ul>

\* OMRON IO-Link products do not support the IO-Link preoperate state.

Sysmac is a trademark or registered trademark of OMRON Corporation in Japan and other countries for OMRON factory automation products.

EtherCAT® is a registered trademark of Beckhoff Automation GmbH for their patented technology.

EtherNet/IP™ is the trademarks of ODVA.

Other company names and product names in this document are the trademarks or registered trademarks of their respective companies.

## System Configuration

Support Software:

- IO-Link Master Unit settings: Use the Sysmac Studio.\*1
- IO-Link device settings: Use CX-ConfiguratorFDT.\*2

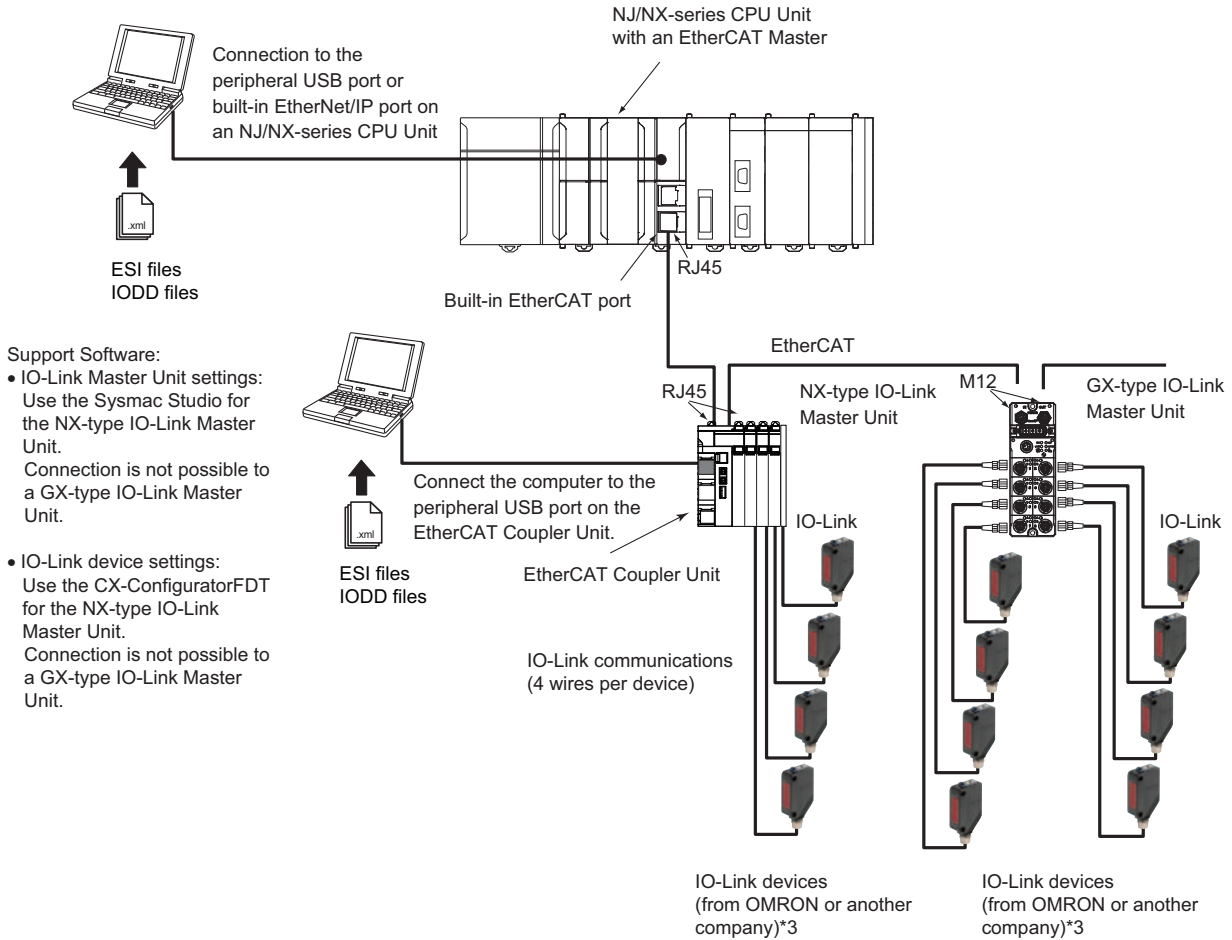

\*1. When a host controller from another company is used with EtherCAT host communications, use the EtherCAT software application from the other company for a GX-type IO-Link Master Unit.

**Note.** For an NX-type IO-Link Master Unit, connect the Sysmac Studio to the EtherCAT Coupler Unit, as shown above.

\*2. When a host controller from another company is used with EtherCAT host communications, for a GX-type IO-Link Master Unit, make the IO-Link device settings with message communications from the host controller from the other company.

**Note.** For an NX-type IO-Link Master Unit, connect CX-ConfiguratorFDT to the EtherCAT Coupler Unit, as shown above.

\*3. You can also connect a combination of general-purpose sensors and other devices.

## Ordering Information

### International Standards

- The standards are abbreviated as follows: U: UL, U1: UL(Class I Division 2 Products for Hazardous Locations), C: CSA, UC: cULus, UC1: cULus (Class I Division 2 Products for Hazardous Locations), CU: cUL, N: NK, L: Lloyd, CE: EU Directives, RCM: RCM mark, and KC: KC Registration.
- Contact your OMRON representative for further details and applicable conditions for these standards.

## NX-series IO-Link Master Unit

Product Name	Specification			Model	Standards
	Number of IO-Link ports	I/O refreshing method	I/O connection terminals		
NX-series IO-Link Master Unit	4	Free-Run refreshing	Screwless clamping terminal block	NX-ILM400	UC1, CE, RCM, KC

## Peripheral Devices

### Sensor I/O Connectors

Order a cable with a connector on one end to connect a sensor. Refer to the *Ordering Information* in the catalog of the sensor to connect or the *Sensor I/O Connectors/Sensor Controllers* on your local OMRON website for recommended products.

## Optional Products

Product name	Specification	Model	Standards
Unit/Terminal Block Coding Pins	Pins for 10 Units (30 terminal block pins and 30 Unit pins)	NX-AUX02	---

Product Name	Specification				Model	Standards
	No. of terminals	Terminal number indications	Ground terminal mark	Terminal current capacity		
Terminal Block	16	A/B	Not provided	10 A	NX-TBA162	---

## Software

### Automation Software Sysmac Studio

Please purchase a DVD and required number of licenses the first time you purchase the Sysmac Studio. DVDs and licenses are available individually. Each model of licenses does not include any DVD.

Product name	Specification		Model	Standards
	Number of licenses	Media		
Sysmac Studio Standard Edition Ver.1.□□	---	DVD	SYSMAC-SE200D	---
	1 license *	---	SYSMAC-SE201L	

\* Multi licenses are available for the Sysmac Studio (3, 10, 30, or 50 licenses).

# NX-ILM400

## General Specification

Item	Specification	
<b>Enclosure</b>	Must be built into a panel.	
<b>Grounding methods</b>	Ground to 100 Ω or less.	
<b>Operating environment</b>	<b>Ambient operating temperature</b>	0 to 55°C
	<b>Ambient operating humidity</b>	10% to 95% (with no condensation or icing)
	<b>Atmosphere</b>	Must be free from corrosive gases.
	<b>Ambient storage temperature</b>	-25 to 70°C (with no condensation or icing)
	<b>Altitude</b>	2,000 m max.
	<b>Pollution degree</b>	Pollution degree 2 or less: Conforms to JIS B3502 and IEC 61131-2.
	<b>Noise immunity</b>	Conforms to IEC 61000-4-4, 2 kV (power line).
	<b>Overvoltage category</b>	Category: Conforms to JIS B3502 and IEC 61131-2.
	<b>EMC immunity level</b>	Zone B
	<b>Vibration resistance</b>	Conforms to IEC 60068-2-6. 5 to 8.4 Hz with amplitude of 3.5 mm, 8.4 to 150 Hz, acceleration of 9.8 m/s <sup>2</sup> 100 min each in X, Y, and Z directions (10 sweeps of 10 min each = 100 min total)
<b>Shock resistance</b>	Conforms to IEC 60068-2-27. 147 m/s <sup>2</sup> , 3 times each in X, Y, and Z directions	
<b>Applicable standards *</b>	UL 61010-2-201, ANSI/ISA 12.12.01, EU: EN 61131-2, RCM, KC, and IO-Link conformance	

\* Refer to the OMRON website ([www.ia.omron.com](http://www.ia.omron.com)) or ask your OMRON representative for the most recent applicable standards for each model.

## Function Specification

Item	Specification	
Unit name	IO-Link Master Unit	
Model	NX-ILM400	
Number of ports	4	
Communications specifications	Communications protocol	IO-Link protocol
	Baud rate	COM1: 4.8kbps COM2: 38.4kbps COM3: 230.4kbps
	Topology	1:1
	Compliant standards	<ul style="list-style-type: none"> <li>IO-Link Interface and System Specification Version1.1.2</li> <li>IO-Link Test Specification Version1.1.2</li> </ul>
Power supply to devices* in IO-Link Mode or SIO (DI) Mode	Rated voltage	24 VDC (20.4 to 28.8 VDC)
	Maximum load current	0.2 A/port
	Short-circuit protection	Provided.
Digital inputs (in SIO (DI) Mode)	Internal I/O common	PNP
	Rated voltage	24 VDC (20.4 to 28.8 VDC)
	Input current	5 mA typical (24 VDC)
	ON voltage/ON current	15 VDC min., 2 mA min.
	OFF voltage	5 VDC max.
	Input filter time	No filter, 0.25 ms, 0.5 ms, 1 ms (default), 2 ms, 4 ms, 8 ms, 16 ms, 32 ms, 64 ms, 128 ms, 256 ms
Digital outputs (in SIO (DO) Mode)	Internal I/O common	PNP
	Output type	Push-pull
	Rated voltage	24 VDC (20.4 to 28.8 VDC)
	Operating load voltage range	20.4 to 28.8 VDC
	Maximum load current	0.1 A/port
	Short-circuit protection	Provided.
	Leakage current	0.1 mA max.
	Residual voltage	1.5 V max.
Digital inputs for pin 2 (in IO-Link Mode)	Internal I/O common	PNP
	Rated voltage	24 VDC (20.4 to 28.8 VDC)
	Input current	2 mA typical (24 VDC)
	ON voltage/ON current	15 VDC min., 2 mA min.
	OFF voltage	5 VDC max.
	Input filter time	No filter, 0.25 ms, 0.5 ms, 1 ms (default), 2 ms, 4 ms, 8 ms, 16 ms, 32 ms, 64 ms, 128 ms, 256 ms
Cable specifications	Cable type	Unshielded
	Length	20 m max.
	Electrostatic capacity between lines	3 nF max.
	Loop resistance	6 Ω max.
External connection terminals	Screwless Clamping Terminal Block (16 terminals)	
I/O refreshing method	Free-Run refreshing	
Dimensions	12 × 100 × 71 mm (W×H×D)	
Isolation method	Photocoupler isolation	
Insulation resistance	20 MΩ min. at 100 VDC (between isolated circuits)	
Dielectric strength	510 VAC for 1 min, leakage current: 5 mA max. (between isolated circuits)	
I/O power supply method	Supply from the NX bus	
NX Unit power consumption	0.80 W	
Current consumption from I/O power supply	50 mA	
Weight	67 g	

Item	Specification																																				
<b>Circuit configuration</b>	<p>Terminal block: C/Q, DI, L+, L-</p> <p>Left-side NX bus connector: I/O power supply +, I/O power supply -</p> <p>Right-side NX bus connector: I/O power supply +, I/O power supply -</p>																																				
<b>Terminal connection diagram</b>	<p>IO-Link Master Unit NX-ILM004</p> <table border="1"> <tr> <td>A1</td> <td>P1_C/Q</td> <td>P2_C/Q</td> <td>B1</td> </tr> <tr> <td></td> <td>P1_DI</td> <td>P2_DI</td> <td></td> </tr> <tr> <td></td> <td>P1_L+</td> <td>P2_L+</td> <td></td> </tr> <tr> <td></td> <td>P1_L-</td> <td>P2_L-</td> <td></td> </tr> <tr> <td></td> <td>P3_C/Q</td> <td>P4_C/Q</td> <td></td> </tr> <tr> <td></td> <td>P3_DI</td> <td>P4_DI</td> <td></td> </tr> <tr> <td></td> <td>P3_L+</td> <td>P4_L+</td> <td></td> </tr> <tr> <td></td> <td>P3_L-</td> <td>P4_L-</td> <td></td> </tr> <tr> <td>A8</td> <td></td> <td></td> <td>B8</td> </tr> </table> <p>IO-Link sensor with DI input: 1 Brown, 4 Black, 2 White, 3 Blue</p> <p>IO-Link sensor without DI input: 1 Brown, 4 Black, 3 Blue</p>	A1	P1_C/Q	P2_C/Q	B1		P1_DI	P2_DI			P1_L+	P2_L+			P1_L-	P2_L-			P3_C/Q	P4_C/Q			P3_DI	P4_DI			P3_L+	P4_L+			P3_L-	P4_L-		A8			B8
A1	P1_C/Q	P2_C/Q	B1																																		
	P1_DI	P2_DI																																			
	P1_L+	P2_L+																																			
	P1_L-	P2_L-																																			
	P3_C/Q	P4_C/Q																																			
	P3_DI	P4_DI																																			
	P3_L+	P4_L+																																			
	P3_L-	P4_L-																																			
A8			B8																																		
<b>Installation orientation and restrictions</b>	<p>Installation orientation: 6 possible orientations Restrictions:</p> <div style="display: flex; justify-content: space-around;"> <div style="text-align: center;"> <p>Upright Installation</p> </div> <div style="text-align: center;"> <p>Any Installation Other Than Upright</p> </div> </div>																																				
<b>Protective functions</b>	<p>Load short-circuit protection</p>																																				

## Function Specifications

Function		Description
Basic Functions	Communications	<b>Cyclic communications</b> I/O data (process data) in the IO-Link devices is cyclically shared with the IO-Link Master Unit as the IO-Link communications master. At the same time, this data and the status of the IO-Link Master Unit is cyclically shared with the host communications master, with the IO-Link Master Unit operating as the host communications slave. Cyclic communications can be used to check the amount of detection performance deterioration in devices, and to check changes in usage conditions, such as the amount of incident light for photoelectric sensors, stability detection margins, and excessive proximity for proximity sensors.
		<b>Message communications</b> The host communications master can send messages (commands) to the IO-Link Master Unit and receive the response from the IO-Link Master Unit. The IO-Link Master Unit can also function as a gateway to send messages (commands and responses) between the host communications master and the IO-Link devices. During operation, you can change and adjust device parameters, such as threshold settings, tuning execution, and ON-delay time changes, from a program. Or, during operation, you can check the internal status, such as the operating times of devices.
	<b>Communications mode settings</b>	You can select any of the following modes for each port: IO-Link Mode, SIO (DI) Mode, SIO (DO) Mode, or Disable Port This allows you to combine IO-Link communications and digital I/O in a single terminal or unit.
	<b>Digital inputs for pin 2</b>	In IO-Link Mode, you can perform digital input with pin 2 while performing IO-Link communications.
	<b>Automatic baud rate setting for IO-Link communications</b>	The IO-Link Master Unit automatically matches the specific baud rates (COM1, COM2, or COM3) of the IO-Link devices to communicate with the IO-Link devices. Therefore, it is not necessary to set the baud rate of the connected device for each port.
	<b>Connected device verification</b>	This function is used to verify the configuration of IO-Link devices that are connected to the IO-Link Master Unit against the registered IO-Link device configuration settings when the power supply is turned ON. The user can enable or disable connected device verification.
	<b>IO-Link communications error detection</b>	This function detects IO-Link cable breaks, disconnections from IO-Link device ports, error-level device events, device configuration verification errors, and IO-Link device malfunctions.
	<b>Detection of short-circuits in I/O cables</b>	This function detects short-circuits in I/O cables
<b>Notification of input data validity</b>	The host controller can use the Input Data Enabled Flags to determine whether input data * is valid. This is not possible if EtherNet/IP is used for host communications.	
Application Functions	<b>Load rejection during host communications error</b>	This function turns OFF outputs from the IO-Link Master Unit when an error occurs in host communications in IO-Link Mode or in an SIO mode. This prevents output operations with incorrect values from host communications.
	<b>Reading IO-Link total communications retries</b>	The IO-Link total communications retries can be read from the CX-ConfiguratorFDT. You can use this function to determine communications status as affected by I/O cable noise or other factors.
	<b>Digital input filter</b>	You can set a filter processing time interval for digital inputs in SIO (DI) Mode or for digital inputs for pin 2 in IO-Link Mode. This lets you eliminate data corruption that can result from noise or switch chattering. This function can also be used to implement an ON delay and an OFF delay.
	<b>Backup and restoration of parameter settings in IO-Link devices</b>	This function is used to back up parameter settings in IO-Link devices in the IO-Link Master Unit or restore them to IO-Link devices. This eliminates the need to set parameters again after replacing an IO-Link device.
	<b>Event log</b>	The event log records events (including errors) that occur in the IO-Link Master Unit and the IO-Link devices. This enables partial troubleshooting for NJ/NX-series Controllers.

\* The input data includes IO-Link input data in IO-Link communications, the digital input data that is input with pin 2, and digital input data in SIO (DI) Mode.

## Version Information

NX Unit		Corresponding Unit Versions/Version *						
		EtherCAT				EtherNet/IP		
Model	Unit version	Communications Coupler Unit	CPU Units	Sysmac Studio	CX-Configurator FDT	Communications Coupler Unit	Sysmac Studio	CX-Configurator FDT
NX-ILM400	Ver.1.0	Ver.1.0 or later	Ver.1.12 or later	Ver.1.16 or higher	Ver.2.2 or higher	Ver.1.0 or later	Ver.1.16 or higher	Ver.2.2 or higher

\* Some Units do not have all of the versions given in the above table. If a Unit does not have the specified version, support is provided by the oldest available version after the specified version. Refer to the user's manuals for the specific Units for the relation between models and versions.

# NX-ILM400

## External Interface

NXILM-400

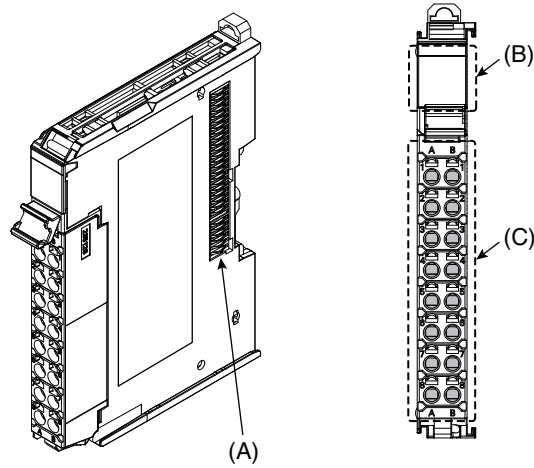

Letter	Name	Function
(A)	NX bus connector	This connector is used to connect each Unit.
(B)	Indicators	The indicators show the current operating status of the Unit.
(C)	Terminal block	The terminal block is used to connect external devices. The number of terminals depends on the type of Unit.

### Terminal Blocks

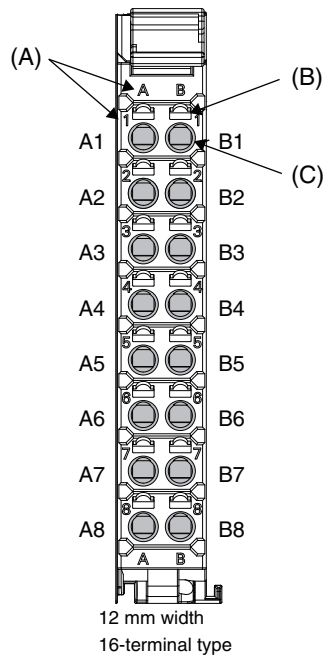

Letter	Name	Function
(A)	Terminal number indications	Terminal numbers for which A and B indicate the column, and 1 to 8 indicate the line are displayed. The terminal number is a combination of column and line, i.e. A1 to A8 and B1 to B8. The terminal number indications are the same regardless of the number of terminals on the terminal block.
(B)	Release holes	Insert a flat-blade screwdriver into these holes to connect and remove the wires.
(C)	Terminal holes	The wires are inserted into these holes.

### Applicable Terminal Blocks for Each Unit Model

Unit model	Terminal Blocks				
	Model	No. of terminals	Terminal number indications	Ground terminal mark	Terminal current capacity
NX-ILM400	NX-TBA162	16	A/B	Not provided	10A



## Applicable Wires

### Using Ferrules

If you use ferrules, attach the twisted wires to them.

Observe the application instructions for your ferrules for the wire stripping length when attaching ferrules.

Always use plated one-pin ferrules. Do not use unplated ferrules or two-pin ferrules.

The applicable ferrules, wires, and crimping tool are given in the following table.

Terminal types	Manufacturer	Ferrule model	Applicable wire (mm <sup>2</sup> (AWG))	Crimping tool
Terminals other than ground terminals	Phoenix Contact	AI0,34-8	0.34 (#22)	Phoenix Contact (The figure in parentheses is the applicable wire size.) CRIMPFOX 6 (0.25 to 6 mm <sup>2</sup> , AWG 24 to 10)
		AI0,5-8	0.5 (#20)	
		AI0,5-10		
		AI0,75-8	0.75 (#18)	
		AI0,75-10		
		AI1,0-8	1.0 (#18)	
		AI1,0-10		
		AI1,5-8	1.5 (#16)	
Ground terminals	Phoenix Contact	AI1,5-10		
		AI2,5-10	2.0 *1	
Terminals other than ground terminals	Weidmuller	H0.14/12	0.14 (#26)	Weidmuller (The figure in parentheses is the applicable wire size.) PZ6 Roto (0.14 to 6 mm <sup>2</sup> , AWG 26 to 10)
		H0.25/12	0.25 (#24)	
		H0.34/12	0.34 (#22)	
		H0.5/14	0.5 (#20)	
		H0.5/16		
		H0.75/14	0.75 (#18)	
		H0.75/16		
		H1.0/14	1.0 (#18)	
		H1.0/16		
		H1.5/14	1.5 (#16)	
		H1.5/16		

\*1. Some AWG 14 wires exceed 2.0 mm<sup>2</sup> and cannot be used in the screwless clamping terminal block.

When you use any ferrules other than those in the above table, crimp them to the twisted wires so that the following processed dimensions are achieved.

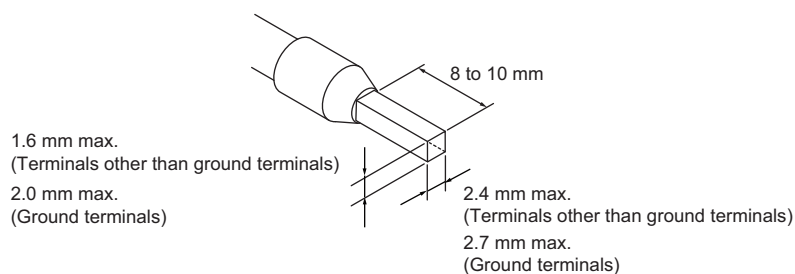

### Using Twisted Wires/Solid Wires

If you use the twisted wires or the solid wires, use the following table to determine the correct wire specifications.

Terminals		Wire type				Wire size	Conductor length (stripping length)
		Twisted wires		Solid wire			
Classification	Current capacity	Plated	Unplated	Plated	Unplated		
All terminals except ground terminals	2 A max.	Possible	Possible	Possible	Possible	0.08 to 1.5 mm <sup>2</sup> AWG28 to 16	8 to 10 mm
	Greater than 2 A and 4 A or less		Not Possible	Possible *1	Not Possible		
	Greater than 4 A		Possible *1	Not Possible	Not Possible		
Ground terminals	---	Possible	Possible	Possible *2	Possible *2	2.0 mm <sup>2</sup>	9 to 10 mm

\*1. Secure wires to the screwless clamping terminal block. Refer to the Securing Wires in the USER'S MANUAL for how to secure wires.

\*2. With the NX-TB□□□□1 Terminal Block, use twisted wires to connect the ground terminal. Do not use a solid wire.

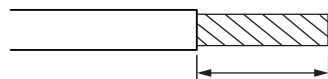

Conductor length (stripping length)

<Additional Information> If more than 2 A will flow on the wires, use plated wires or use ferrules.

# NX-ILM400

## Dimensions

(Unit: mm)

NX-ILM400  
12 mm Width

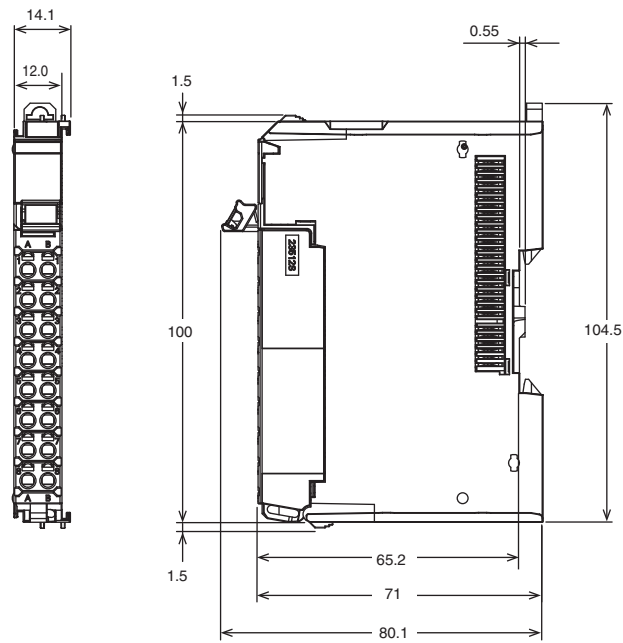

## Related Manuals

Man.No	Model	Manual	Application	Description
W567	NX-ILM400	IO-Link Master Unit User's Manual	Learning hardware information, wiring, and specifications for the NX-series IO-Link Master Unit and checking a list of NX objects.	Describes detailed part specifications, installation, and wiring and also provides tables of specifications and NX objects for the NX-series IO-Link Master Unit.
W570	NX-ILM400 GX-ILM08C	IO-Link System User's Manual	Learning everything from an introduction to details about IO-Link Systems, including mainly software information common to all IO-Link masters, Support Software operating methods, and troubleshooting. <b>Note:</b> Refer to the manuals for the individual Master Units for hardware information specific to each Master Unit and a list of the objects for each Master Unit.	Provides an overview of IO-Link Systems and explains the system configuration, communications specifications, communications methods, I/O data, parameters, models, Support Software, and troubleshooting. Refer to the following manuals for the individual IO-Link Master Units for hardware information and specifications specific to each Master Unit and a list of the NX objects for each Master Unit. NX-series IO-Link Master Unit: W568 GX-series IO-Link Master Unit: W488-E1-05 or later
W488-E1-05	GX-ID □□□□ GX-OD □□□□ GX-OC □□□□ GX-MD □□□□ GX-AD □□□□ GX-DA □□□□ GX-EC □□□□ GX-ILM □□□□ XWT-ID □□ XWT-OD □□	EtherCAT Slave Units User's Manual	Learning hardware information on the GX-series IO-Link Master Unit and checking a list of objects.	Describes part names, functions, installation, and wiring and also provides tables of specifications and NX objects for the NX-series IO-Link Master Unit (W488-E1-05 or later). Also describes the hardware, setup methods, and functions of the EtherCAT Remote I/O Terminals.
W502	NX701-□□□□ NJ501-□□□□ NJ301-□□□□ NJ101-□□□□	NJ/NX-series Instructions Reference Manual	Learning detailed specifications on the basic instructions of an NJ/NX-series CPU Unit.	The instructions in the instruction set (IEC 61131-3 specifications) are described. When programming, use this manual together with the <i>NX-series CPU Unit Hardware User's Manual</i> (Cat. No. W535) or <i>NJ-series CPU Unit Hardware User's Manual</i> (Cat. No. W500) and <i>NJ/NX-series CPU Unit Software User's Manual</i> (Cat. No. W501).
W505	NX701-□□□□ NJ501-□□□□ NJ301-□□□□ NJ101-□□□□	NJ/NX-series CPU Unit Built-in EtherCAT® Port User's Manual	Using the built-in EtherCAT port on an NJ/NX-series CPU Unit.	Information on the built-in EtherCAT port is provided. This manual provides an introduction and provides information on the configuration, features, and setup. Use this manual together with the <i>NX-series CPU Unit Hardware User's Manual</i> (Cat. No. W535) or <i>NJ-series CPU Unit Hardware User's Manual</i> (Cat. No. W500) and <i>NJ/NX-series CPU Unit Software User's Manual</i> (Cat. No. W501).
W503	NX701-□□□□ NJ501-□□□□ NJ301-□□□□ NJ101-□□□□	NJ/NX-series Troubleshooting Manual	Learning about the errors that may be detected in an NJ/NX-series Controller.	Concepts on managing errors that may be detected in an NJ/NX-series Controller and information on individual errors are described. Use this manual together with the <i>NX-series CPU Unit Hardware User's Manual</i> (Cat. No. W535) or <i>NJ-series CPU Unit Hardware User's Manual</i> (Cat. No. W500) and <i>NJ/NX-series CPU Unit Software User's Manual</i> (Cat. No. W501).
W525	NX- □□□□□□	NX-series Data Reference Manual	Referencing lists of the data that is required to configure systems with NX-series Units	Lists of the power consumptions, weights, and other NX Unit data that is required to configure systems with NX-series Units are provided.
W519	NX-ECC□□□	NX-series EtherCAT® Coupler Unit User's Manual	Learning how to use an NX-series EtherCAT Coupler Unit and EtherCAT Slave Terminals	The system and configuration of EtherCAT Slave Terminals, which consist of an NX-series EtherCAT Coupler Unit and NX Units, are described along with the hardware, setup, and functions of the EtherCAT Coupler Unit that are required to configure, control, and monitor NX Units through EtherCAT.
W504	SYSMAC-SE2□□□	Sysmac Studio Version 1 Operation Manual	Learning about the operating procedures and functions of the Sysmac Studio.	Describes the operating procedures of the Sysmac Studio.

**Note:** Refer to the instructions for the individual Sensors for information on IO-Link Sensors.



**IO-Link makes sensor level information visible and solves the three major issues at manufacturing sites!**

**The Unit for M12 Smartclick Connector Can Be Used in Watery, and Dusty Environments.**



- Downtime can be reduced.  
Notifies you of faulty parts and such phenomena in the Sensor in real time.
- The frequency of sudden failure can be decreased.  
Condition monitoring of sensors and equipment to prevent troubles.
- The efficiency of changeover can be improved.  
The batch check for individual sensor IDs significantly decreases commissioning time.

## Features

- The host controller can cyclically read control signals, status\*1, wiring, and power supply status of IO-Link sensors. Because an IO-Link System can cyclically read analog data such as the amount of incident light in addition to ON/OFF information, it can be used for predictive maintenance based on detection of such things as decreases in the amount of light.
- User-specified data in IO-Link devices can be read and written from the host controller when necessary.
- Digital signals can be input rapidly from IO-Link sensors\*2 during IO-Link communications.
- IO-Link sensors can be combined with non-IO-Link sensors.
- Incorrect connections of IO-Link sensors can be checked when IO-Link communications start.
- Backup and restoration of IO-Link device parameters\*3 make replacement of IO-Link sensors easier.
- Sensors can report their errors to the master, which facilitates locating errors from the host.
- The total number of retries in cyclic communications can be recorded. You can use this value to check for the influences of noise and other problems.  
(When EtherCAT is used as the host communication interface) \*3
- Up to eight sensors can be connected. IP67 protection.

\*1. Examples for Photoelectric Sensors: Instability detection and sensor errors

\*2. IO-Link sensors that support digital inputs that use pin 2 of IO-Link Master Unit ports

\*3. When the Omron IO-Link master unit is used

## Communications Specifications

Item	Specification
Communications protocol	IO-Link protocol
Baud rate	COM1 (4.8 kbps), COM2 (38.4 kbps), or COM3 (230.4 kbps)
Topology	1:1
Communications media	Unshielded cable
Communications distance	20 m max.
Compliant standards	<ul style="list-style-type: none"> <li>• IO-Link Interface and System Specification Version1.1.2 *</li> <li>• IO-Link Test Specification Version1.1.2</li> </ul>

\* OMRON IO-Link products do not support the IO-Link preoperate state.

Sysmac is a trademark or registered trademark of OMRON Corporation in Japan and other countries for OMRON factory automation products.

EtherCAT® is a registered trademark of Beckhoff Automation GmbH for their patented technology.

EtherNet/IP™ is the trademarks of ODVA.

Other company names and product names in this document are the trademarks or registered trademarks of their respective companies.

## System Configuration

Support Software:

- IO-Link Master Unit settings: Use the Sysmac Studio.\*1
- IO-Link device settings: Use CX-ConfiguratorFDT.\*2

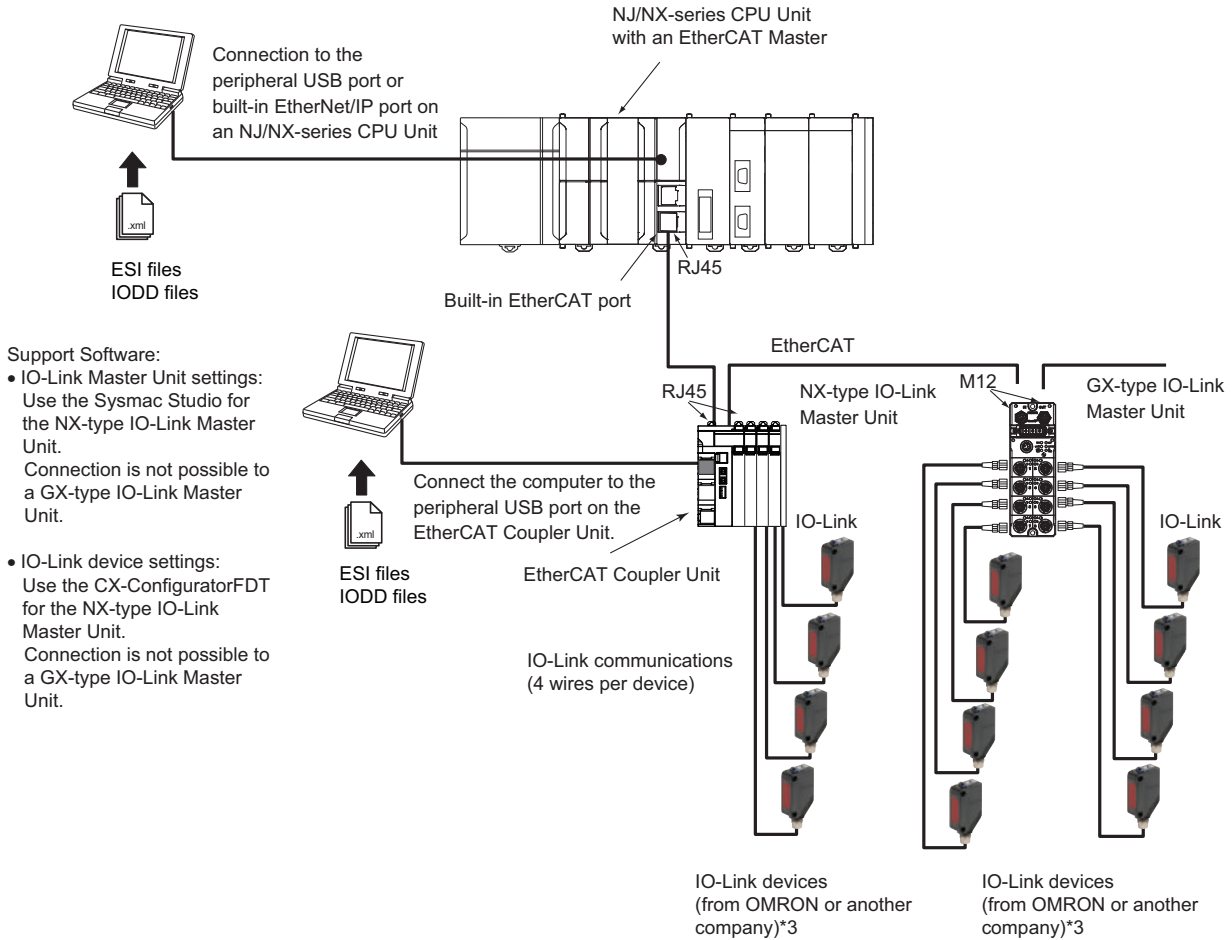

\*1. When a host controller from another company is used with EtherCAT host communications, use the EtherCAT software application from the other company for a GX-type IO-Link Master Unit.

**Note.** For an NX-type IO-Link Master Unit, connect the Sysmac Studio to the EtherCAT Coupler Unit, as shown above.

\*2. When a host controller from another company is used with EtherCAT host communications, for a GX-type IO-Link Master Unit, make the IO-Link device settings with message communications from the host controller from the other company.

**Note.** For an NX-type IO-Link Master Unit, connect CX-ConfiguratorFDT to the EtherCAT Coupler Unit, as shown above.

\*3. You can also connect a combination of general-purpose sensors and other devices.

## Ordering Information

### International Standards

- The standards are abbreviated as follows: U: UL, U1: UL(Class I Division 2 Products for Hazardous Locations), C: CSA, UC: cULus, UC1: cULus (Class I Division 2 Products for Hazardous Locations), CU: cUL, N: NK, L: Lloyd, CE: EU Directives, RCM: RCM mark, and KC: KC Registration.
- Contact your OMRON representative for further details and applicable conditions for these standards.



## EtherCAT Slave Terminals IO-Link Master Unit

Product Name	Specification			Model	Standards
	Environmental resistance	Number of IO-Link ports	I/O connection terminals		
GX-series IO-Link Master Unit	IP67	8	M12 connector (A-cording, female)	GX-ILM08C	CE, RCM, KC

## Peripheral Devices

### Recommended EtherCAT Communications Cables

Use Straight STP (shielded twisted-pair) cable of category 5 or higher with double shielding (braiding and aluminum foil tape) for EtherCAT.

Item	Appearance	Recommended manufacturer	Cable length (m)	Model
Cable with Connectors on Both Ends Shield Strengthening cable Wire Gauge and Number of Pairs: AWG22, 2-pair Cable Cable color: Black	 Smartclick (M12 Straight/M12 straight)	OMRON	0.5	XS5W-T421-BM2-SS
			1	XS5W-T421-CM2-SS
			2	XS5W-T421-DM2-SS
			3	XS5W-T421-EM2-SS
			5	XS5W-T421-GM2-SS
			10	XS5W-T421-JM2-SS
Cable with Connectors on Both Ends Rugged type Shield Strengthening cable Wire Gauge and Number of Pairs: AWG22, 2-pair Cable Cable color: Black	 Smartclick (M12 Straight/RJ45 straight)	OMRON	0.5	XS5W-T421-BMC-SS
			1	XS5W-T421-CMC-SS
			2	XS5W-T421-DMC-SS
			3	XS5W-T421-EMC-SS
			5	XS5W-T421-GMC-SS
			10	XS5W-T421-JMC-SS

**Note:** For details, Contact your OMRON representative.

### Sensor I/O Connectors

Item	Appearance	Recommended manufacturer	Cable length (m)	Model
Connector connected to cable, socket on one cable end Fire-retardant, Robot cable	Smartclick (M12 Straight)	OMRON	1	XS5F-D421-C80-F
			2	XS5F-D421-D80-F
			3	XS5F-D421-E80-F
			5	XS5F-D421-G80-F
			10	XS5F-D421-J80-F
Connectors connected to cable, socket and plug on cable ends Fire-retardant, Robot cable	Smartclick (M12 Straight/M12 straight)	OMRON	1	XS5W-D421-C81-F
			2	XS5W-D421-D81-F
			3	XS5W-D421-E81-F
			5	XS5W-D421-G81-F
			10	XS5W-D421-J81-F

**Note:** Refer to the *Round Water-resistant Connectors* in the category of *Sensor I/O Connector/Sensor Controller* on your local OMRON website for details.

### Sensor I/O Connectors

Order a cable with a connector on both ends to connect a sensor.

Item	Appearance	Recommended manufacturer	Cable length (m)	Model
Connectors connected to cable, M8 socket and M12 plug on cable ends Fire-retardant, Robot cable	M8 screw- M12 Smartclick (M8 Straight/M12 straight)	OMRON	0.2	XS3W-M42C-4C2-A
Connectors connected to cable, socket and plug on cable ends Fire-retardant, Robot cable	Smartclick (M12 Straight/M12 straight)	OMRON	1	XS5W-D421-C81-F
			2	XS5W-D421-D81-F
			3	XS5W-D421-E81-F
			5	XS5W-D421-G81-F
			10	XS5W-D421-J81-F

**Note:** Refer to the *Ordering Information* in the catalog of the sensor to connect or the *Sensor I/O Connectors/Sensor Controllers* on your local OMRON website for details.

**Software**

**Automation Software Sysmac Studio**

Please purchase a DVD and required number of licenses the first time you purchase the Sysmac Studio. DVDs and licenses are available individually. Each model of licenses does not include any DVD.

Product name	Specification		Model	Standards	
	Number of licenses	Media			
Sysmac Studio Standard Edition Ver.1.□□	The Sysmac Studio is the software that provides an integrated environment for setting, programming, debugging and maintenance of machine automation controllers including the NJ/NX-series, EtherCAT Slave, and the HMI.	--- (Media only)	DVD	SYSMAC-SE200D	---
	Sysmac Studio runs on the following OS. Windows XP (Service Pack 3 or higher, 32-bit version)/Windows Vista(32-bit version)/ Windows 7(32-bit/64-bit version)/Windows 8(32-bit/64-bit version)/Windows 8.1(32-bit/64-bit version)/Windows 10(32-bit/64-bit version)	1 license *	---	SYSMAC-SE201L	

\* Multi licenses are available for the Sysmac Studio (3, 10, 30, or 50 licenses).



## General Specification

Item	Specification
Unit power supply voltage	20.4 to 26.4 VDC (24 VDC -15%/+10%)
I/O power supply	20.4 to 26.4 VDC (24 VDC -15%/+10%)
Noise resistance	Conforms to IEC 61000-4-4, 2 kV (power line).
Vibration resistance	Malfunction: 10 to 60 Hz with amplitude of 0.7 mm, 60 to 150 Hz and 50 m/s <sup>2</sup> for 80 minutes each in X, Y, and Z directions
Shock resistance	150 m/s <sup>2</sup> with amplitude of 0.7 mm
Dielectric strength	600 VAC (between isolated circuits)
Insulation resistance	20 MΩ min. (between isolated circuits)
Ambient operating temperature	-10 to 55°C
Ambient operating humidity	25% to 85% (with no condensation)
Ambient operating atmosphere	No corrosive gases
Storage temperature	-25 to 65°C
Storage humidity	25% to 85% (with no condensation)
Degree of protection	IP67
Mounting	M5 screw mounting
Mounting strength	100 N
Communications connector strength	30 N
Connector types	Connectors for EtherCAT communications: M12 (D-coding, female) × 2 Power supply connector: M12 (A-coding, male) × 1 I/O connectors: M12 (A-coding, female)*1 × 8
Screw tightening torque *2	Round connectors (communications connector, power supply, and I/O): 0.39 to 0.49 N·m M5 (Unit mounted from the front): 1.47 to 1.96 N·m Cover for node address setting switches: 0.4 to 0.6 N·m
Applicable standards *3	EU: EN 61131-2, RCM, KC, IO-Link conformance, and EtherCAT conformance

\*1. Confirms to Class A when used as an IO-Link connector.

\*2. For SmartClick Connectors, insert the Connector all the way and turn it approx. 1/8 of a turn. Torque management is not required.

\*3. Refer to the OMRON website ([www.ia.omron.com](http://www.ia.omron.com)) or ask your OMRON representative for the most recent applicable standards for each model.

# GX-ILM08C

## Function Specification

Item	Specification	
Unit name	IO-Link Master Unit	
Model	GX-ILM08C	
Number of IO-Link ports	8	
Communications specifications	Communications protocol	IO-Link protocol
	Baud rate	COM1: 4.8 kbps COM2: 38.4 kbps COM3: 230.4 kbps
	Topology	1:1
	Compliant standards	<ul style="list-style-type: none"> <li>IO-Link Interface and System Specification Version 1.1.2</li> <li>IO-Link Test Specification Version 1.1.2</li> </ul>
Device power supply* in IO-Link Mode or SIO (DI) Mode	Rated voltage	24 VDC (20.4 to 26.4 VDC)
	Maximum load current	0.2 A/port
	Short-circuit protection	Yes
Digital inputs (in SIO (DI) Mode)	Internal I/O common	PNP
	Rated voltage	24 VDC (20.4 to 26.4 VDC)
	Input current	5 mA typical (at 24 VDC)
	ON voltage/ON current	15 VDC min., 5 mA min.
	OFF voltage	5 VDC max.
	Input filter time	No filter, 0.25 ms, 0.5 ms, 1 ms (default), 2 ms, 4 ms, 8 ms, 16 ms, 32 ms, 64 ms, 128 ms, or 256 ms
Digital outputs (in SIO (DIO) Mode)	Internal I/O common	PNP
	Output type	Push-pull
	Rated voltage	24 VDC (20.4 to 26.4 VDC)
	Maximum load current	0.3 A/port
	Short-circuit protection	Provided.
	Leakage current	0.1 mA max.
	Residual voltage	1.5 V max.
Digital inputs for pin 2 (in IO-Link Mode)	Internal I/O common	PNP
	Rated voltage	24 VDC (20.4 to 26.4 VDC)
	Input current	2 mA (24 VDC)
	ON voltage/ON current	15 VDC min., 2 mA min.
	OFF voltage	5 VDC max.
	Input filter time	No filter, 0.25 ms, 0.5 ms, 1 ms (default), 2 ms, 4 ms, 8 ms, 16 ms, 32 ms, 64 ms, 128 ms, or 256 ms
Cable specifications	Cable type	Unshielded
	Cable length	20 m max.
	Electrostatic capacity between lines	3 nF max.
	Loop resistance	6 Ω max.
Dimensions	175 × 33 × 60 mm (W×H×D) (The height is 49.1 mm when the connectors are included.)	
Isolation method	Photocoupler isolation	
I/O power supply method	Supplied from the power supply connector.	
Unit power supply current consumption	60 mA	
I/O power supply current consumption	100 mA	
Weight	430 g	
Circuit layout	<p>The diagram illustrates the internal circuitry of the GX-ILM08C. It shows a power supply connector on the left that provides two sets of power: 'Unit power supply' (24V and 0V) and 'I/O power supply' (24V and 0V). The 24V unit power supply is connected to 'Non-isolated power supply circuits'. The 0V unit power supply is connected to 'Internal circuits' and 'IO-LINK circuits'. The 24V I/O power supply is connected to 'Non-isolated power supply circuits' and 'IO-LINK circuits'. The 0V I/O power supply is connected to 'IO-LINK circuits'. The 'IO-LINK circuits' are connected to 'I/O connector 1' and 'I/O connector 8'. Each connector has terminals for L+, C/Q, DI, and L-. The 'Internal circuits' and 'IO-LINK circuits' are connected via an 'Isolation circuit'.</p>	
Installation orientation and restrictions	Installation orientation: 6 possible orientations Restrictions: No restrictions	
Protective functions	Load short-circuit protection	

## Function Specifications

Function		Description
Basic Functions	Communications	<b>Cyclic communications</b> I/O data (process data) in the IO-Link devices is cyclically shared with the IO-Link Master Unit as the IO-Link communications master. At the same time, this data and the status of the IO-Link Master Unit is cyclically shared with the host communications master, with the IO-Link Master Unit operating as the host communications slave. Cyclic communications can be used to check the amount of detection performance deterioration in devices, and to check changes in usage conditions, such as the amount of incident light for photoelectric sensors, stability detection margins, and excessive proximity for proximity sensors.
		<b>Message communications</b> The host communications master can send messages (commands) to the IO-Link Master Unit and receive the response from the IO-Link Master Unit. The IO-Link Master Unit can also function as a gateway to send messages (commands and responses) between the host communications master and the IO-Link devices. During operation, you can change and adjust device parameters, such as threshold settings, tuning execution, and ON-delay time changes, from a program. Or, during operation, you can check the internal status, such as the operating times of devices.
	<b>Communications mode settings</b>	You can select any of the following modes for each port: IO-Link Mode, SIO (DI) Mode, SIO (DO) Mode, or Disable Port This allows you to combine IO-Link communications and digital I/O in a single terminal or unit.
	<b>Digital inputs for pin 2</b>	In IO-Link Mode, you can perform digital input with pin 2 while performing IO-Link communications.
	<b>Automatic baud rate setting for IO-Link communications</b>	The IO-Link Master Unit automatically matches the specific baud rates (COM1, COM2, or COM3) of the IO-Link devices to communicate with the IO-Link devices. Therefore, it is not necessary to set the baud rate of the connected device for each port.
	<b>Connected device verification</b>	This function is used to verify the configuration of IO-Link devices that are connected to the IO-Link Master Unit against the registered IO-Link device configuration settings when the power supply is turned ON. The user can enable or disable connected device verification.
	<b>IO-Link communications error detection</b>	This function detects IO-Link cable breaks, disconnections from IO-Link device ports, error-level device events, device configuration verification errors, and IO-Link device malfunctions.
	<b>Detection of short-circuits in I/O cables</b>	This function detects short-circuits in I/O cables
<b>Notification of input data validity</b>	The host controller can use the Input Data Enabled Flags to determine whether input data * is valid. This is not possible if EtherNet/IP is used for host communications.	
Application Functions	<b>Load rejection during host communications error</b>	This function turns OFF outputs from the IO-Link Master Unit when an error occurs in host communications in IO-Link Mode or in an SIO mode. This prevents output operations with incorrect values from host communications.
	<b>Reading IO-Link total communications retries</b>	The IO-Link total communications retries can be read from the CX-ConfiguratorFDT. You can use this function to determine communications status as affected by I/O cable noise or other factors.
	<b>Digital input filter</b>	You can set a filter processing time interval for digital inputs in SIO (DI) Mode or for digital inputs for pin 2 in IO-Link Mode. This lets you eliminate data corruption that can result from noise or switch chattering. This function can also be used to implement an ON delay and an OFF delay.
	<b>Backup and restoration of parameter settings in IO-Link devices</b>	This function is used to back up parameter settings in IO-Link devices in the IO-Link Master Unit or restore them to IO-Link devices. This eliminates the need to set parameters again after replacing an IO-Link device.
	<b>Event log</b>	The event log records events (including errors) that occur in the IO-Link Master Unit and the IO-Link devices. This enables partial troubleshooting for NJ/NX-series Controllers.

\* The input data includes IO-Link input data in IO-Link communications, the digital input data that is input with pin 2, and digital input data in SIO (DI) Mode.

# GX-ILM08C

## EtherCAT Communications Specifications

Item	Specification
Communications protocol	EtherCAT protocol
Modulation	Baseband
Baud rate	100 Mbps
Physical layer	100BASE-TX (IEEE 802.3)
Connectors	M12 (D-coding, female) × 2 (shielded) CN IN: EtherCAT input CN OUT: EtherCAT output
Communications media	Category 5 or higher (cable with double, aluminum tape and braided shielding is recommended.)
Communications distance	Distance between nodes (Slave Units): 100 m max.
Noise resistance	Conforms to IEC 61000-4-4, 1 kV or higher.
Node address setting method	Set on hexadecimal node address switches or with a Configuration Tool.
Node address range	000 to FFF hex (0 to 4,095 decimal): Set on node address switches or with a Configuration Tool.
Indicators	UNIT PWR × 1 IO PWR × 1 L/A IN (Link/Activity IN) × 1 L/A OUT (Link/Activity OUT) × 1 RUN × 1 ERR × 1
Process data	Variable PDO mapping
PDO size/node	2 to 270 bytes
Mailbox	Emergency messages, SDO requests, SDO responses, and SDO information
Synchronization mode	Free Run Mode (asynchronous)

## Version Information

GX Unit		Corresponding Unit Versions/Version *		
		EtherCAT		
Model	Unit version	CPU Units	Sysmac Studio	CX-Configurator FDT
GX-ILM08C	Ver.1.0	Ver.1.12 or later	Ver.1.16 or higher	Ver.2.2 or higher

\* Some Units do not have all of the versions given in the above table. If a Unit does not have the specified version, support is provided by the oldest available version after the specified version. Refer to the user's manuals for the specific Units for the relation between models and versions.

## Component Names and Functions

### GX-ILM08C

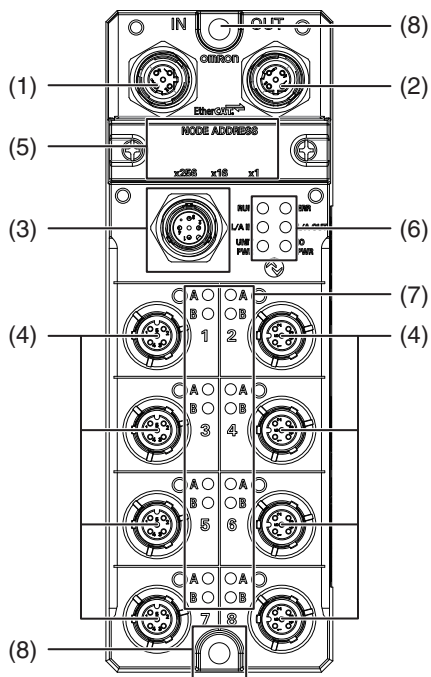

No.	Name	Function
(1)	EtherCAT communications connector, IN	EtherCAT cable connection: IN side M12 connector (D-coding, female)
(2)	EtherCAT communications connector, OUT	EtherCAT cable connection: OUT side M12 connector (D-coding, female)
(3)	Power supply connector	Connects to Unit power supply and I/O power supply cable. M12 connector (A-coding, male)
(4)	I/O connectors	Connect to IO-Link sensor cables (IO-Link connector type: Class A) M12 connectors (A-coding, female)
(5)	Node address setting switches	Used to set the EtherCAT node address.
(6)	Status indicators	Indicate the current status of the EtherCAT Slave Unit. (RUN, ERR, L/A IN, L/A OUT, UNIT PWR, and I/O PWR)
(7)	I/O indicators	Indicate the I/O status. (C/E and C/Q)
(8)	Mounting holes	Used to mount the Unit with M5 screws.

# GX-ILM08C

## Wiring

### IO-Link Mode

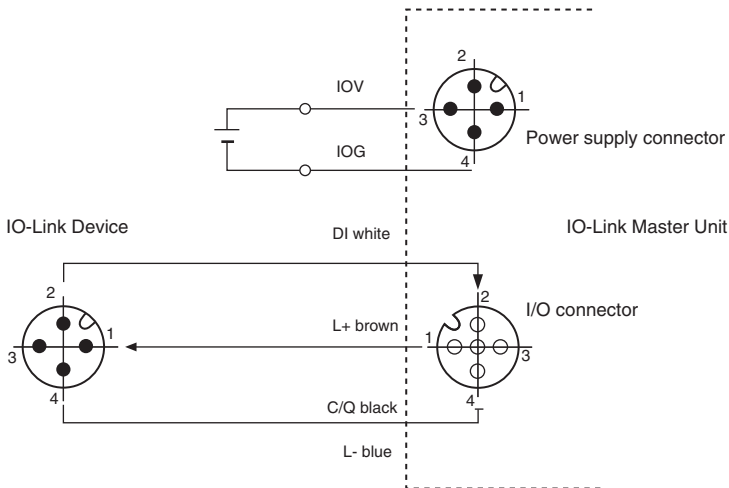

**Note:** Even if you connect to IO-Link devices without digital inputs for pin 2, connect pin 2 as shown in the above figure. This is because connectors on the IO-Link devices and the cable with connectors on both ends connect pin 2. However, because no data enters pin 2 of the IO-Link Master Unit, digital IO-Link input data is always OFF.

### SIO (DI) Mode

#### Wiring Three-wire Sensors

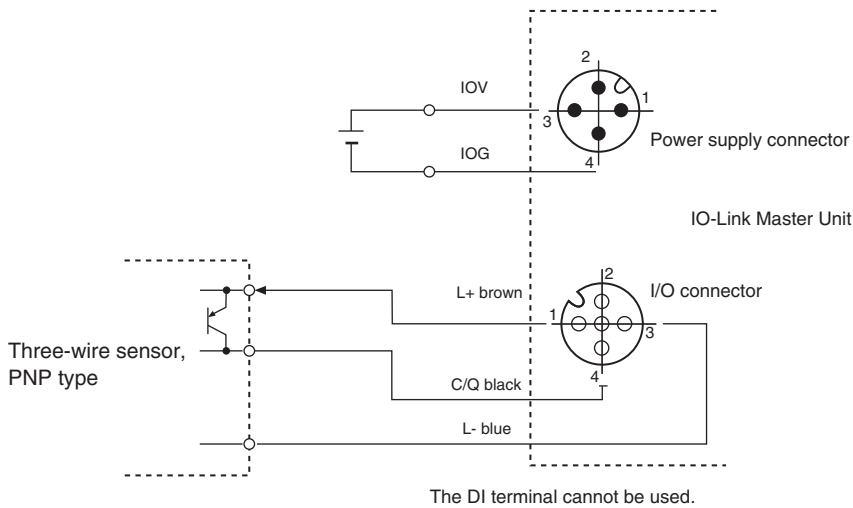

#### Wiring Two-wire Sensors

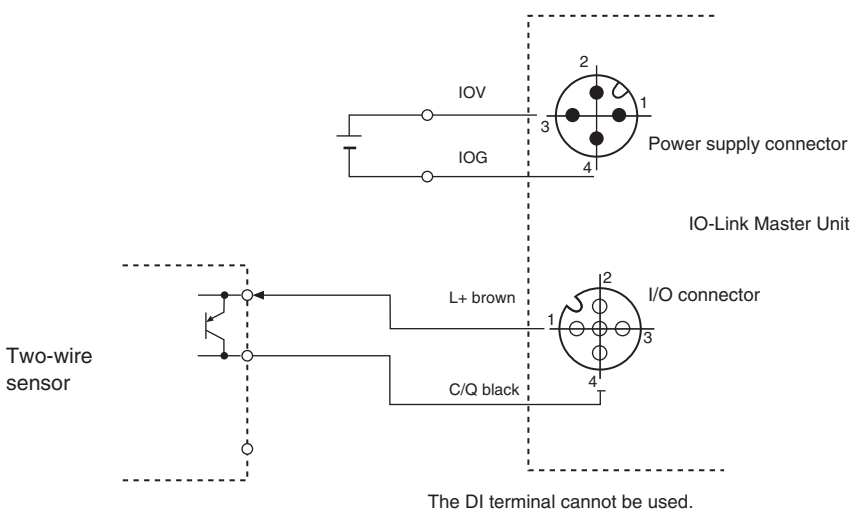

## SIO (DO) Mode

### Wiring Output Devices

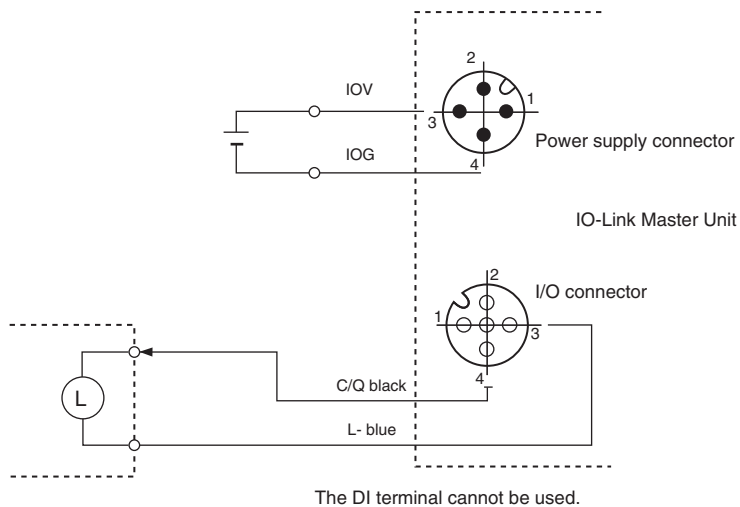

## Dimensions

(Unit: mm)

### GX-ILM08C

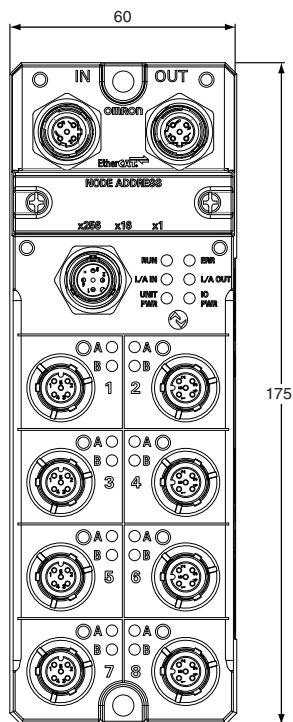

Height: 33 (49.1 mm when the connectors are included)

## Related Manuals

Man.No	Model	Manual	Application	Description
W488-E1-05	GX-ID □□□□ GX-OD □□□□ GX-OC □□□□ GX-MD □□□□ GX-AD □□□□ GX-DA □□□□ GX-EC □□□□ GX-ILM □□□ XWT-ID □□ XWT-OD □□	EtherCAT Slave Units User's Manual	Learning hardware information on the GX-series IO-Link Master Unit and checking a list of objects.	Describes part names, functions, installation, and wiring and also provides tables of specifications and NX objects for the NX-series IO-Link Master Unit (W488-E1-05 or later). Also describes the hardware, setup methods, and functions of the EtherCAT Remote I/O Terminals.
W570	NX-ILM400 GX-ILM08C	IO-Link System User's Manual	Learning everything from an introduction to details about IO-Link Systems, including mainly software information common to all IO-Link masters, Support Software operating methods, and troubleshooting. <b>Note:</b> Refer to the manuals for the individual Master Units for hardware information specific to each Master Unit and a list of the objects for each Master Unit.	Provides an overview of IO-Link Systems and explains the system configuration, communications specifications, communications methods, I/O data, parameters, models, Support Software, and troubleshooting. Refer to the following manuals for the individual IO-Link Master Units for hardware information and specifications specific to each Master Unit and a list of the NX objects for each Master Unit. NX-series IO-Link Master Unit: W568 GX-series IO-Link Master Unit: W488-E1-05 or later
W567	NX-ILM400	IO-Link Master Unit User's Manual	Learning hardware information, wiring, and specifications for the NX-series IO-Link Master Unit and checking a list of NX objects.	Describes detailed part specifications, installation, and wiring and also provides tables of specifications and NX objects for the NX-series IO-Link Master Unit.
W502	NX701-□□□□ NJ501-□□□□ NJ301-□□□□ NJ101-□□□□	NJ/NX-series Instructions Reference Manual	Learning detailed specifications on the basic instructions of an NJ/NXseries CPU Unit.	The instructions in the instruction set (IEC 61131-3 specifications) are described. When programming, use this manual together with the <i>NX-series CPU Unit Hardware User's Manual</i> (Cat. No. W535) or <i>NJ-series CPU Unit Hardware User's Manual</i> (Cat. No. W500) and <i>NJ/NX-series CPU Unit Software User's Manual</i> (Cat. No. W501).
W505	NX701-□□□□ NJ501-□□□□ NJ301-□□□□ NJ101-□□□□	NJ/NX-series CPU Unit Built-in EtherCAT® Port User's Manual	Using the built-in EtherCAT port on an NJ/NX-series CPU Unit.	Information on the built-in EtherCAT port is provided. This manual provides an introduction and provides information on the configuration, features, and setup. Use this manual together with the <i>NX-series CPU Unit Hardware User's Manual</i> (Cat. No. W535) or <i>NJ-series CPU Unit Hardware User's Manual</i> (Cat. No. W500) and <i>NJ/NX-series CPU Unit Software User's Manual</i> (Cat. No. W501).
W503	NX701-□□□□ NJ501-□□□□ NJ301-□□□□ NJ101-□□□□	NJ/NX-series Troubleshooting Manual	Learning about the errors that may be detected in an NJ/NX-series Controller.	Concepts on managing errors that may be detected in an NJ/NX-series Controller and information on individual errors are described. Use this manual together with the <i>NX-series CPU Unit Hardware User's Manual</i> (Cat. No. W535) or <i>NJ-series CPU Unit Hardware User's Manual</i> (Cat. No. W500) and <i>NJ/NX-series CPU Unit Software User's Manual</i> (Cat. No. W501).
W525	NX-□□□□□□	NX-series Data Reference Manual	Referencing lists of the data that is required to configure systems with NX-series Units.	Lists of the power consumptions, weights, and other NX Unit data that is required to configure systems with NX-series Units are provided.
W519	NX-ECC□□□	NX-series EtherCAT® Coupler Unit User's Manual	Learning how to use an NX-series EtherCAT Coupler Unit and EtherCAT Slave Terminals.	The system and configuration of EtherCAT Slave Terminals, which consist of an NX-series EtherCAT Coupler Unit and NX Units, are described along with the hardware, setup, and functions of the EtherCAT Coupler Unit that are required to configure, control, and monitor NX Units through EtherCAT.
W504	SYSMAC-SE2□□□	Sysmac Studio Version 1 Operation Manual	Learning about the operating procedures and functions of the Sysmac Studio.	Describes the operating procedures of the Sysmac Studio.



# Terms and Conditions of Sale

1. **Offer; Acceptance.** These terms and conditions (these "**Terms**") are deemed part of all quotes, agreements, purchase orders, acknowledgments, price lists, catalogs, manuals, brochures and other documents, whether electronic or in writing, relating to the sale of products or services (collectively, the "**Products**") by Omron Electronics LLC and its subsidiary companies ("**Omron**"). Omron objects to any terms or conditions proposed in Buyer's purchase order or other documents which are inconsistent with, or in addition to, these Terms.
2. **Prices; Payment Terms.** All prices stated are current, subject to change without notice by Omron. Omron reserves the right to increase or decrease prices on any unshipped portions of outstanding orders. Payments for Products are due net 30 days unless otherwise stated in the invoice.
3. **Discounts.** Cash discounts, if any, will apply only on the net amount of invoices sent to Buyer after deducting transportation charges, taxes and duties, and will be allowed only if (i) the invoice is paid according to Omron's payment terms and (ii) Buyer has no past due amounts.
4. **Interest.** Omron, at its option, may charge Buyer 1-1/2% interest per month or the maximum legal rate, whichever is less, on any balance not paid within the stated terms.
5. **Orders.** Omron will accept no order less than \$200 net billing.
6. **Governmental Approvals.** Buyer shall be responsible for, and shall bear all costs involved in, obtaining any government approvals required for the importation or sale of the Products.
7. **Taxes.** All taxes, duties and other governmental charges (other than general real property and income taxes), including any interest or penalties thereon, imposed directly or indirectly on Omron or required to be collected directly or indirectly by Omron for the manufacture, production, sale, delivery, importation, consumption or use of the Products sold hereunder (including customs duties and sales, excise, use, turnover and license taxes) shall be charged to and remitted by Buyer to Omron.
8. **Financial.** If the financial position of Buyer at any time becomes unsatisfactory to Omron, Omron reserves the right to stop shipments or require satisfactory security or payment in advance. If Buyer fails to make payment or otherwise comply with these Terms or any related agreement, Omron may (without liability and in addition to other remedies) cancel any unshipped portion of Products sold hereunder and stop any Products in transit until Buyer pays all amounts, including amounts payable hereunder, whether or not then due, which are owing to it by Buyer. Buyer shall in any event remain liable for all unpaid accounts.
9. **Cancellation; Etc.** Orders are not subject to rescheduling or cancellation unless Buyer indemnifies Omron against all related costs or expenses.
10. **Force Majeure.** Omron shall not be liable for any delay or failure in delivery resulting from causes beyond its control, including earthquakes, fires, floods, strikes or other labor disputes, shortage of labor or materials, accidents to machinery, acts of sabotage, riots, delay in or lack of transportation or the requirements of any government authority.
11. **Shipping; Delivery.** Unless otherwise expressly agreed in writing by Omron:
  - a. Shipments shall be by a carrier selected by Omron; Omron will not drop ship except in "break down" situations.
  - b. Such carrier shall act as the agent of Buyer and delivery to such carrier shall constitute delivery to Buyer;
  - c. All sales and shipments of Products shall be FOB shipping point (unless otherwise stated in writing by Omron), at which point title and risk of loss shall pass from Omron to Buyer; provided that Omron shall retain a security interest in the Products until the full purchase price is paid;
  - d. Delivery and shipping dates are estimates only; and
  - e. Omron will package Products as it deems proper for protection against normal handling and extra charges apply to special conditions.
12. **Claims.** Any claim by Buyer against Omron for shortage or damage to the Products occurring before delivery to the carrier must be presented in writing to Omron within 30 days of receipt of shipment and include the original transportation bill signed by the carrier noting that the carrier received the Products from Omron in the condition claimed.
13. **Warranties.** (a) **Exclusive Warranty.** Omron's exclusive warranty is that the Products will be free from defects in materials and workmanship for a period of twelve months from the date of sale by Omron (or such other period expressed in writing by Omron). Omron disclaims all other warranties, express or implied. (b) **Limitations.** OMRON MAKES NO WARRANTY OR REPRESENTATION, EXPRESS OR IMPLIED, ABOUT NON-INFRINGEMENT, MERCHANTABILITY OR FITNESS FOR A PARTICULAR PURPOSE OF THE PRODUCTS. BUYER ACKNOWLEDGES THAT IT ALONE HAS DETERMINED THAT THE PRODUCTS WILL SUITABLY MEET THE REQUIREMENTS OF THEIR INTENDED USE. Omron further disclaims all warranties and responsibility of any type for claims or expenses based on infringement by the Products or otherwise of any intellectual property right. (c) **Buyer Remedy.** Omron's sole obligation hereunder shall be, at Omron's election, to (i) replace (in the form originally shipped with Buyer responsible for labor charges for removal or replacement thereof) the non-complying Product, (ii) repair the non-complying Product, or (iii) repay or credit Buyer an amount equal to the purchase price of the non-complying Product; provided that in no event shall Omron be responsible for warranty, repair, indemnity or any other claims or expenses regarding the Products unless Omron's analysis confirms that the Products were properly handled, stored, installed and maintained and not subject to contamination, abuse, misuse or inappropriate modification. Return of any Products by Buyer must be approved in writing by Omron before shipment. Omron Companies shall not be liable for the suitability or unsuitability or the results from the use of Products in combination with any electrical or electronic components, circuits, system assemblies or any other materials or substances or environments. Any advice, recommendations or information given orally or in writing, are not to be construed as an amendment or addition to the above warranty. See <http://www.omron247.com> or contact your Omron representative for published information.
14. **Limitation on Liability; Etc.** OMRON COMPANIES SHALL NOT BE LIABLE FOR SPECIAL, INDIRECT, INCIDENTAL, OR CONSEQUENTIAL DAMAGES, LOSS OF PROFITS OR PRODUCTION OR COMMERCIAL LOSS IN ANY WAY CONNECTED WITH THE PRODUCTS, WHETHER SUCH CLAIM IS BASED IN CONTRACT, WARRANTY, NEGLIGENCE OR STRICT LIABILITY. Further, in no event shall liability of Omron Companies exceed the individual price of the Product on which liability is asserted.
15. **Indemnities.** Buyer shall indemnify and hold harmless Omron Companies and their employees from and against all liabilities, losses, claims, costs and expenses (including attorney's fees and expenses) related to any claim, investigation, litigation or proceeding (whether or not Omron is a party) which arises or is alleged to arise from Buyer's acts or omissions under these Terms or in any way with respect to the Products. Without limiting the foregoing, Buyer (at its own expense) shall indemnify and hold harmless Omron and defend or settle any action brought against such Companies to the extent based on a claim that any Product made to Buyer specifications infringed intellectual property rights of another party.
16. **Property; Confidentiality.** Any intellectual property in the Products is the exclusive property of Omron Companies and Buyer shall not attempt to duplicate it in any way without the written permission of Omron. Notwithstanding any charges to Buyer for engineering or tooling, all engineering and tooling shall remain the exclusive property of Omron. All information and materials supplied by Omron to Buyer relating to the Products are confidential and proprietary, and Buyer shall limit distribution thereof to its trusted employees and strictly prevent disclosure to any third party.
17. **Export Controls.** Buyer shall comply with all applicable laws, regulations and licenses regarding (i) export of products or information; (ii) sale of products to "forbidden" or other proscribed persons; and (iii) disclosure to non-citizens of regulated technology or information.
18. **Miscellaneous.** (a) **Waiver.** No failure or delay by Omron in exercising any right and no course of dealing between Buyer and Omron shall operate as a waiver of rights by Omron. (b) **Assignment.** Buyer may not assign its rights hereunder without Omron's written consent. (c) **Law.** These Terms are governed by the law of the jurisdiction of the home office of the Omron company from which Buyer is purchasing the Products (without regard to conflict of law principles). (d) **Amendment.** These Terms constitute the entire agreement between Buyer and Omron relating to the Products, and no provision may be changed or waived unless in writing signed by the parties. (e) **Severability.** If any provision hereof is rendered ineffective or invalid, such provision shall not invalidate any other provision. (f) **Setoff.** Buyer shall have no right to set off any amounts against the amount owing in respect of this invoice. (g) **Definitions.** As used herein, "including" means "including without limitation"; and "Omron Companies" (or similar words) mean Omron Corporation and any direct or indirect subsidiary or affiliate thereof.

## Certain Precautions on Specifications and Use

1. **Suitability of Use.** Omron Companies shall not be responsible for conformity with any standards, codes or regulations which apply to the combination of the Product in the Buyer's application or use of the Product. At Buyer's request, Omron will provide applicable third party certification documents identifying ratings and limitations of use which apply to the Product. This information by itself is not sufficient for a complete determination of the suitability of the Product in combination with the end product, machine, system, or other application or use. Buyer shall be solely responsible for determining appropriateness of the particular Product with respect to Buyer's application, product or system. Buyer shall take application responsibility in all cases but the following is a non-exhaustive list of applications for which particular attention must be given: (i) Outdoor use, uses involving potential chemical contamination or electrical interference, or conditions or uses not described in this document. (ii) Use in consumer products or any use in significant quantities. (iii) Energy control systems, combustion systems, railroad systems, aviation systems, medical equipment, amusement machines, vehicles, safety equipment, and installations subject to separate industry or government regulations. (iv) Systems, machines and equipment that could present a risk to life or property. Please know and observe all prohibitions of use applicable to this Product. NEVER USE THE PRODUCT FOR AN APPLICATION INVOLVING SERIOUS RISK TO LIFE OR PROPERTY OR IN LARGE QUANTITIES WITHOUT ENSURING THAT THE SYSTEM AS A WHOLE HAS BEEN DESIGNED TO ADDRESS THE RISKS, AND THAT THE OMRON'S PRODUCT IS PROPERLY RATED AND INSTALLED FOR THE INTENDED USE WITHIN THE OVERALL EQUIPMENT OR SYSTEM.
2. **Programmable Products.** Omron Companies shall not be responsible for the user's programming of a programmable Product, or any consequence thereof.
3. **Performance Data.** Data presented in Omron Company websites, catalogs and other materials is provided as a guide for the user in determining suitability and does not constitute a warranty. It may represent the result of Omron's test conditions, and the user must correlate it to actual application requirements. Actual performance is subject to the Omron's Warranty and Limitations of Liability.
4. **Change in Specifications.** Product specifications and accessories may be changed at any time based on improvements and other reasons. It is our practice to change part numbers when published ratings or features are changed, or when significant construction changes are made. However, some specifications of the Product may be changed without any notice. When in doubt, special part numbers may be assigned to fix or establish key specifications for your application. Please consult with your Omron's representative at any time to confirm actual specifications of purchased Product.
5. **Errors and Omissions.** Information presented by Omron Companies has been checked and is believed to be accurate; however, no responsibility is assumed for clerical, typographical or proofreading errors or omissions.

**OMRON AUTOMATION AMERICAS HEADQUARTERS** • Chicago, IL USA • 847.843.7900 • 800.556.6766 • [www.omron247.com](http://www.omron247.com)

**OMRON CANADA, INC. • HEAD OFFICE**

Toronto, ON, Canada • 416.286.6465 • 866.986.6766 • [www.omron247.com](http://www.omron247.com)

**OMRON ELECTRONICS DE MEXICO • HEAD OFFICE**

México DF • 52.55.59.01.43.00 • 01-800-226-6766 • [mela@omron.com](mailto:mela@omron.com)

**OMRON ELECTRONICS DE MEXICO • SALES OFFICE**

Apodaca, N.L. • 52.81.11.56.99.20 • 01-800-226-6766 • [mela@omron.com](mailto:mela@omron.com)

**OMRON ELETRÔNICA DO BRASIL LTDA • HEAD OFFICE**

São Paulo, SP, Brasil • 55.11.2101.6300 • [www.omron.com.br](http://www.omron.com.br)

**OMRON ARGENTINA • SALES OFFICE**

Cono Sur • 54.11.4783.5300

**OMRON CHILE • SALES OFFICE**

Santiago • 56.9.9917.3920

**OTHER OMRON LATIN AMERICA SALES**

54.11.4783.5300

**OMRON EUROPE B.V.** • Wegalaan 67-69, NL-2132 JD, Hoofddorp, The Netherlands. • +31 (0) 23 568 13 00 • [www.industrial.omron.eu](http://www.industrial.omron.eu)

*Authorized Distributor:*

**Controllers & I/O**

- Machine Automation Controllers (MAC) • Motion Controllers
- Programmable Logic Controllers (PLC) • Temperature Controllers • Remote I/O

**Robotics**

- Industrial Robots • Mobile Robots

**Operator Interfaces**

- Human Machine Interface (HMI)

**Motion & Drives**

- Machine Automation Controllers (MAC) • Motion Controllers • Servo Systems
- Frequency Inverters

**Vision, Measurement & Identification**

- Vision Sensors & Systems • Measurement Sensors • Auto Identification Systems

**Sensing**

- Photoelectric Sensors • Fiber-Optic Sensors • Proximity Sensors
- Rotary Encoders • Ultrasonic Sensors

**Safety**

- Safety Light Curtains • Safety Laser Scanners • Programmable Safety Systems
- Safety Mats and Edges • Safety Door Switches • Emergency Stop Devices
- Safety Switches & Operator Controls • Safety Monitoring/Force-guided Relays

**Control Components**

- Power Supplies • Timers • Counters • Programmable Relays
- Digital Panel Meters • Monitoring Products

**Switches & Relays**

- Limit Switches • Pushbutton Switches • Electromechanical Relays
- Solid State Relays

**Software**

- Programming & Configuration • Runtime