

# Panasonic INSTRUCTION MANUAL

## Digital Fiber Sensor Amplifier FX-400 Series

MJE-FX411 No.0034-50V

Thank you very much for purchasing Panasonic products. Please read this Instruction Manual carefully and thoroughly for the correct and optimum use of this product. Kindly keep this manual in a convenient place for quick reference.

### WARNING

- Never use this product as a sensing device for personnel protection.
- In case of using sensing devices for personnel protection, use products which meet laws and standards, such as OSHA, ANSI or IEC etc., for personnel protection applicable in each region or country.

## 1 PART DESCRIPTION

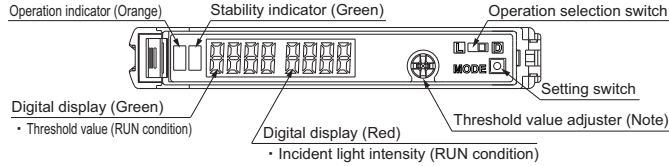

## 2 MOUNTING

Make sure that the power supply is off while connecting / disconnecting the amplifiers and the quick-connection cables.

### How to mount the amplifier

- 1 Fit the rear part of the mounting section of the amplifier on a DIN rail.
- 2 Press down the rear part of the mounting section of the unit on the DIN rail and fit the front part of the mounting section to the DIN rail.

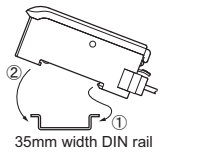

### How to remove the amplifier

- 1 Push the amplifier forward.
- 2 Lift up the front part of the amplifier to remove it.

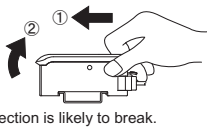

Note: Take care that if the front part is lifted without pushing the amplifier forward, the hook on the rear portion of the mounting section is likely to break.

### How to connect the fiber cables

Be sure to fit the attachment to the fibers first before inserting the fibers to the amplifier. For details, refer to the instruction manual enclosed with the fibers.

- 1 Snap the fiber lock lever down.
- 2 Insert the fiber cables slowly into the inlets until they stop. (Note 1)
- 3 Return the fiber lock lever to the original position, till it stops.

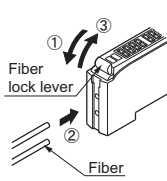

Notes: 1) In case the fiber cables are not inserted to a position where they stop, the sensing range reduces. In case of a flexible fiber, take care that it may bend inside the amplifier, during insertion.  
2) With the coaxial reflective type fiber, such as, FD-G4 or FD-FM2, insert the single-core fiber cable into the beam-emitting inlet and the multi-core fiber cable into the beam-receiving inlet. If they are inserted in reverse, the sensing accuracy will deteriorate.

## 3 CASCADING

- Make sure that the power supply is off while adding or removing the amplifiers.
- Make sure to check the allowable ambient temperature, as it depends on the number of amplifiers connected in cascade.
- In case two, or more, amplifiers are connected in cascade, make sure to mount them on a DIN rail.
- When the amplifiers move on the DIN rail depending on the attaching condition or the amplifiers are mounted close to each other in cascade, fit them between the optional end plates (MS-DIN-E) mounted at the two ends.
- Up to maximum 15 amplifiers can be added (total 16 amplifiers connected in cascade.)
- When connecting more than two amplifiers in cascade, use the sub cable (CN-71-C□) as the quick-connection cable for the second amplifier onwards.
- When connecting amplifiers not close to each other in parallel, be sure to mount the optional end plate (MS-DIN-E) at both sides of each amplifier or affix the communication window seal of the optional amplifier protection seal (FX-MB1) to the communication windows. For details, refer to the instruction manual enclosed with the FX-MB1.
- When the connector type and the cable type or different LED (red / blue / green) types are connected in cascade, mount the identical models together.
- When this product is used with the other digital fiber amplifiers, be sure to place this product to the left most position (When you look from the connector side). If this product is not placed to the leftmost position, this product may not operate properly.

For mounting and removing the amplifier, refer to '2 MOUNTING'.

### Cascading method

- 1 Mount the amplifiers, one by one, on the DIN rail.
- 2 Slide the amplifiers next to each other, and connect the quick-connection cables.
- 3 Mount the optional end plates (MS-DIN-E) at both the ends to hold the amplifiers between their flat sides.
- 4 Tighten the screws to fix the end plates.

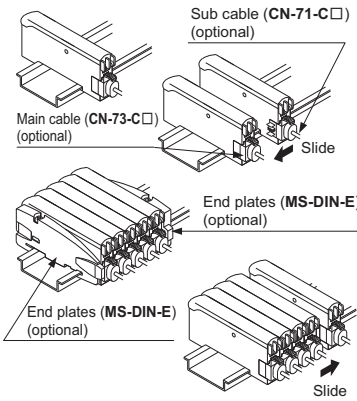

### Dismantling

- 1 Loosen the screws of the end plates.
- 2 Remove the end plates.
- 3 Slide the amplifiers and remove them one by one.

## 4 I/O CIRCUIT DIAGRAMS

Make sure that the power supply is off while wiring.

### ● NPN output type

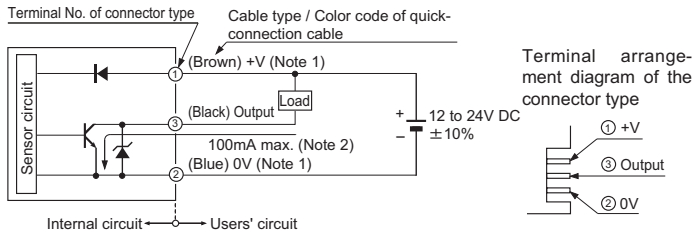

### ● PNP output type

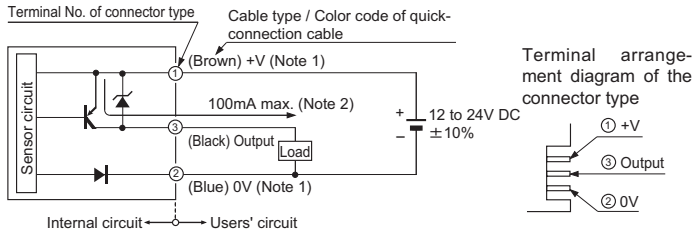

Notes: 1) The quick-connection sub cable does not have +V (brown) and 0V (blue). The power is supplied from the connector of the main cable.  
2) 50mA max., if five, or more, the connector type amplifiers are connected in cascade.

## 5 SWITCHING OUTPUT OPERATION

- The operation selection switch can be used to display different output operations (L-ON / D-ON) on the digital display.



## 6 THRESHOLD VALUE (SENSITIVITY) ADJUSTMENT

- 1 Check the incident light intensity [in the digital display (red)] when a sensing object is placed in the sensing position.
- 2 Check the incident light intensity [in the digital display (red)] when the sensing object is removed from the sensing position.
- 3 Turn the threshold value adjuster to the threshold value [in the digital display (green)] that is the value in between ① and ②. (The threshold value is automatically written to the EEPROM.)

### <Threshold value setting method>

- When the threshold value adjuster is turned clockwise, the threshold value increases. When the threshold value adjuster is turned counterclockwise, the threshold value decreases.

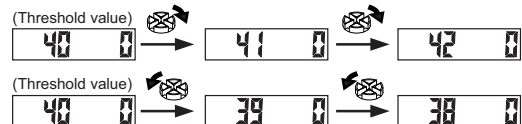

If there is a sufficient level of margin in the incident light intensity, the stability indicator (green) will light up.

## 7 MODE SELECTION

- When the setting switch is pressed and held for 2 sec. or more, 'SET' mode (mode setting screen) is activated.
- If the setting switch is pressed while in 'SET' mode, the mode will change.
- If the threshold value adjuster is turned while a mode is active, the setting item will change and blink.
- When the setting switch is pressed at the item you would like to set, it blinks 3 times and then the setting is confirmed and the mode switches to the next mode.
- If the setting switch is pressed and held for 2 sec. or more or do not press any key for 15 sec. while 'SET' mode is active, the mode will switch automatically to 'RUN' mode.

### ● Mode table

Mode	Factory setting	Description	Connector type			Cable type		
			Red LED	Blue LED	Green LED	Red LED	Blue LED	Green LED
Response time change mode	SPEd Std	The response time can be set.	FX-411	FX-411B	FX-411G	FX-411-C2	FX-411B-C2	FX-411G-C2
Emitting intensity selection mode (Note 1)	Pcct: 10000	The light emitting intensity can be switched among four levels.	FX-411P	FX-411BP	FX-411GP	FX-411P-C2	FX-411BP-C2	FX-411GP-C2
Timer setting mode	dELy non	Timer settings can be selected; Without timer / OFF-delay timer / ON-delay timer / ONE-SHOT timer. Also the timer period can be set.						
Digital display inversion mode	turn OFF	The display on the digital display can be inverted.						
Eco mode (Note 2)	Eco OFF	If no key is pressed for approximately 20 sec. while in 'RUN' mode, the digital display turns off automatically. Press the setting switch or move the operation selection switch to make the display light up again. The digital display will light up when the threshold value adjuster is turned, but note that this will also cause the threshold value to change.						
Peak / Bottom hold mode	Hold OFF	If the setting switch is pressed while 'RUN' mode is active, the display will alternate between the peak hold value and the bottom hold value. (The display will refresh every 2 sec.) The display will return to normal if any operation other than threshold value setting is carried out.						

Notes: 1) This mode is not incorporated in the blue LED type and green LED type.  
2) While the peak / bottom hold mode is ON, the digital display is not turned off even if the Eco mode is set to ON.

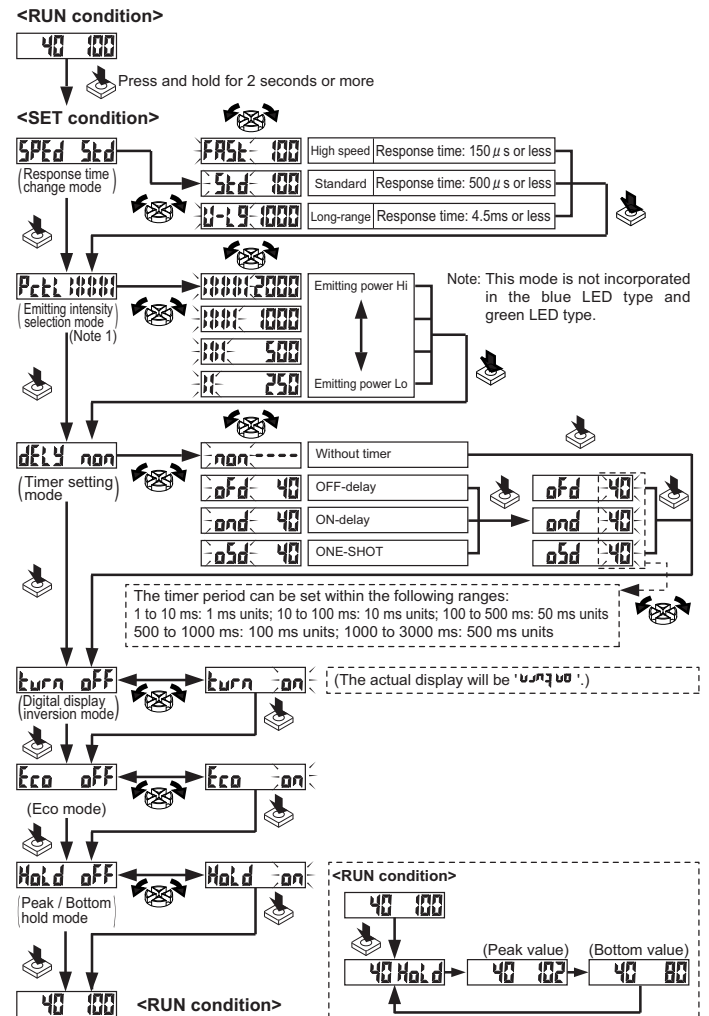

## 8 KEY LOCK FUNCTION

- When the setting switch is pressed and held for 5 sec. while in 'RUN' mode, the key lock function can be set / canceled.
- When the key lock function is set to ON, even if the threshold value adjuster or the setting switch is operated, 'Loc' is displayed and the key operation cannot be carried out.

Note: Although the display changes to the indication of 'SET' condition 2 sec. after pressing the setting switch, keep pressing the switch. Furthermore, the sensor does not go into the key lock setting from 'SET' condition.

## 9 FACTORY SETTING

- When the setting switch is pressed and held for 10 sec., until '-----' is displayed while in 'RUN' mode, the all settings are returned to the factory setting. (For the factory setting, refer to '● Mode table' in '7 MODE SELECTION'.)

## 10 ERROR DISPLAY INDICATOR READINGS

Display	Error description	Measures
E-1	The load has short-circuited and excess current is flowing.	Turn off the power, then check the load.
E-5	Communication error has occurred at time of connection.	Check if the mounted amplifiers are in close contact with each other.

## 11 SPECIFICATIONS

Model No.	Type	Connector type			Cable type		
		Red LED	Blue LED	Green LED	Red LED	Blue LED	Green LED
Item No.	NPN output (Note 1)	FX-411	FX-411B	FX-411G	FX-411-C2	FX-411B-C2	FX-411G-C2
	PNP output	FX-411P	FX-411BP	FX-411GP	FX-411P-C2	FX-411BP-C2	FX-411GP-C2
Supply voltage		12 to 24V DC ± 10% Ripple P-P 10% or less					
Power consumption		<Red LED type> • Normal operation: 960mW or less (Current consumption 40mA or less at 24V supply voltage) • ECO mode: 840mW or less (Current consumption 35mA or less at 24V supply voltage)			<Blue LED type / Green LED type> • Normal operation: 720mW or less (Current consumption 30mA or less at 24V supply voltage) • ECO mode: 580mW or less (Current consumption 24mA or less at 24V supply voltage)		
Output		<NPN output type> NPN open-collector transistor • Maximum sink current: 100mA (Note 2) • Applied voltage: 30V DC or less (between output and 0V) • Residual voltage: 1.5V or less [at 100mA (Note 2) sink current]			<PNP output type> PNP open-collector transistor • Maximum source current: 100mA (Note 2) • Applied voltage: 30V DC or less (between output and +V) • Residual voltage: 1.5V or less [at 100mA (Note 2) source current]		
Output operation		Light-ON or Dark-ON, selectable with switch					
Short-circuit protection		Incorporated					
Response time		FAST: 150 μs or less, STD: 500 μs or less, U-LG: 4.5ms or less selectable with switch					
Interference prevention function		Incorporated [up to four fibers can be mounted adjacently (However, U-LG mode is eight fibers)]					
Ambient temperature		-10 to +55°C (If 4 to 7 units are connected in cascade: -10 to +50°C, if 8 to 16 units are connected in cascade: -10 to +45°C) (No dew condensation or icing allowed), Storage: -20 to +70°C					
Ambient humidity		35 to 85% RH, Storage: 35 to 85% RH					
Emitting element		Red LED	Blue LED	Green LED	Red LED	Blue LED	Green LED
Peak emission wavelength		650nm	470nm	525nm	650nm	470nm	525nm
Material		Enclosure: Heat-resistant ABS, Transparent cover: Polycarbonate Setting switch: Heat-resistant ABS, Threshold value adjuster: Polycarbonate					
Cable		0.3mm <sup>2</sup> 3-core cable, 2m long (Cable type only)					
Weight		20g approx.			60g approx.		

Notes: 1) FX-412□, with the sensitivity adjuster shaped so that it can be turned manually using fingers, is also available. However, the cable type is not available for FX-412□.  
2) 50mA, the connector type five, or more, amplifiers are connected in cascade.  
3) When the power supply is switched on, the light emission timing is automatically set for interference prevention.  
4) The cable for amplifier connection is not supplied as an accessory. Make sure to use the optional quick-connection cables given below.  
Main cable (3-core): CN-73-C1 (cable length 1m), CN-73-C2 (cable length 2m), CN-73-C5 (cable length 5m)  
Sub cable (1-core): CN-71-C1 (cable length 1m), CN-71-C2 (cable length 2m), CN-71-C5 (cable length 5m)

## 12 CAUTIONS

- This product has been developed / produced for industrial use only.
- Take care that wrong wiring will damage the sensor.
- Make sure that the power supply is off while wiring.
- Verify that the supply voltage variation is within the rating.
- Take care that if a voltage exceeding the rated range is applied, or if an AC power supply is directly connected, the sensor may get burnt or damaged.
- In case noise generating equipment (switching regulator, inverter motor, etc.) is used in the vicinity of this product, connect the frame ground (F.G.) terminal of the equipment to an actual ground.
- If power is supplied from a commercial switching regulator, ensure that the frame ground (F.G.) terminal of the power supply is connected to an actual ground.
- Do not use during the initial transient time (0.5 sec.) after the power supply is switched on.
- Take care that short-circuit of the load or wrong wiring may burn or damage the sensor.
- Do not run the wires together with high-voltage lines or power lines or put them in the same raceway. This can cause malfunction due to induction.
- Extension up to total 100m (if 5 to 8 units are connected in cascade: 50m, if 9 to 16 units are connected in cascade: 20m) is possible with 0.3mm<sup>2</sup>, or more, cable. However, in order to reduce noise, make the wiring as short as possible.
- Take care that cable extension increases the residual voltage.
- This sensor is suitable for indoor use only.
- Avoid dust, dirt, and steam.
- Take care that the product does not come in contact with water, oil, grease, organic solvents, such as, thinner, etc., strong acid or alkaline.
- This sensor cannot be used in an environment containing inflammable or explosive gases.
- Never disassemble or modify the sensor.
- The changes to the settings are written to the EEPROM, but because the EEPROM has a limited service life, you should avoid changing the settings any more than 1 million times.

## 13 INTENDED PRODUCTS FOR CE MARKING

- The models listed under "11 SPECIFICATIONS" come with CE Marking. As for all other models, please contact our office.



● Contact for CE  
<Until June 30, 2013>  
Panasonic Electric Works Europe AG  
Rudolf-Diesel-Ring 2, D-83607 Holzkirchen, Germany  
<From July 1, 2013>  
Panasonic Marketing Europe GmbH Panasonic Testing Center  
Winsbergring 15, 22525 Hamburg, Germany

## Panasonic Industrial Devices SUNX Co., Ltd.

http://panasonic.net/id/pidsx/global

Overseas Sales Division (Head Office)  
2431-1 Ushiyama-cho, Kasugai-shi, Aichi, 486-0901, Japan  
Phone: +81-568-33-7861 FAX: +81-568-33-8591

About our sale network, please visit our website.

PRINTED IN JAPAN

© Panasonic Industrial Devices SUNX Co., Ltd. 2012